

SR127 - KR127

PORTAVALIGIA SPECIFICO - SPECIFIC CASE HOLDER  
PORTE-VAISE SPECIFIQUE - SPEZIFISCHER KOFFER-TRÄGER  
PORTA-EQUIPAJE ESPECIFICO

# GILERA GP800 2008

ISTRUZIONI DI MONTAGGIO - MOUNTING INSTRUCTIONS  
INSTRUCTIONS DE MONTAGE - BAUANLEITUNG - INSTRUCCIONES DE MONTAJE

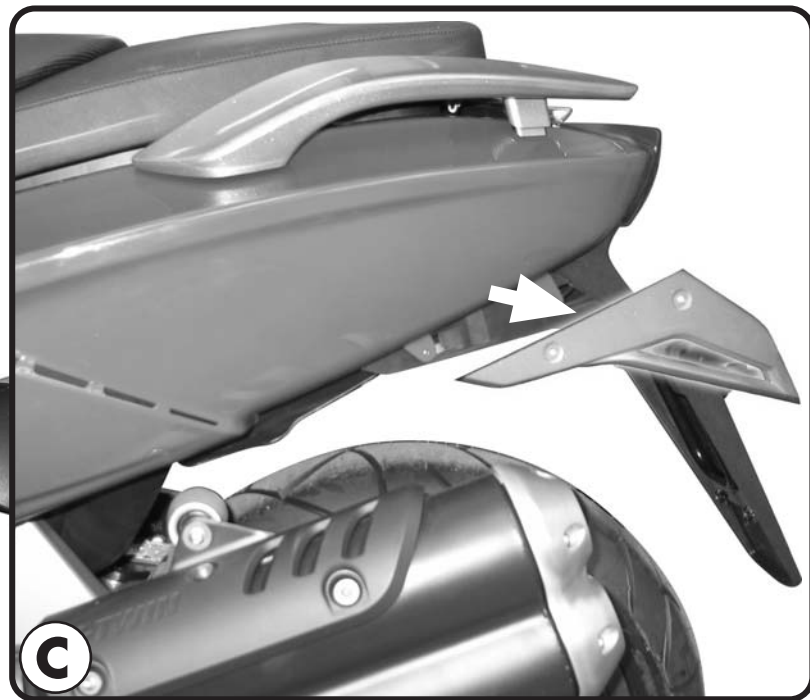

**ATTENZIONE:** PESO  
MASSIMO  
SOPPORTABILE  
10Kg.

**WARNING:**  
MAX. LOADING OF  
THE CARRIER  
10Kg. (21lbs)

**ATTENTION:**  
CHARGE MAXIMALE  
10Kg.

**ACHTUNG:**  
MAXIMALE  
BELASTUNG 10Kg.

**¡ATENCIÓN!:** CARGA  
MAXIMA  
AUTORIZADA 10Kg.

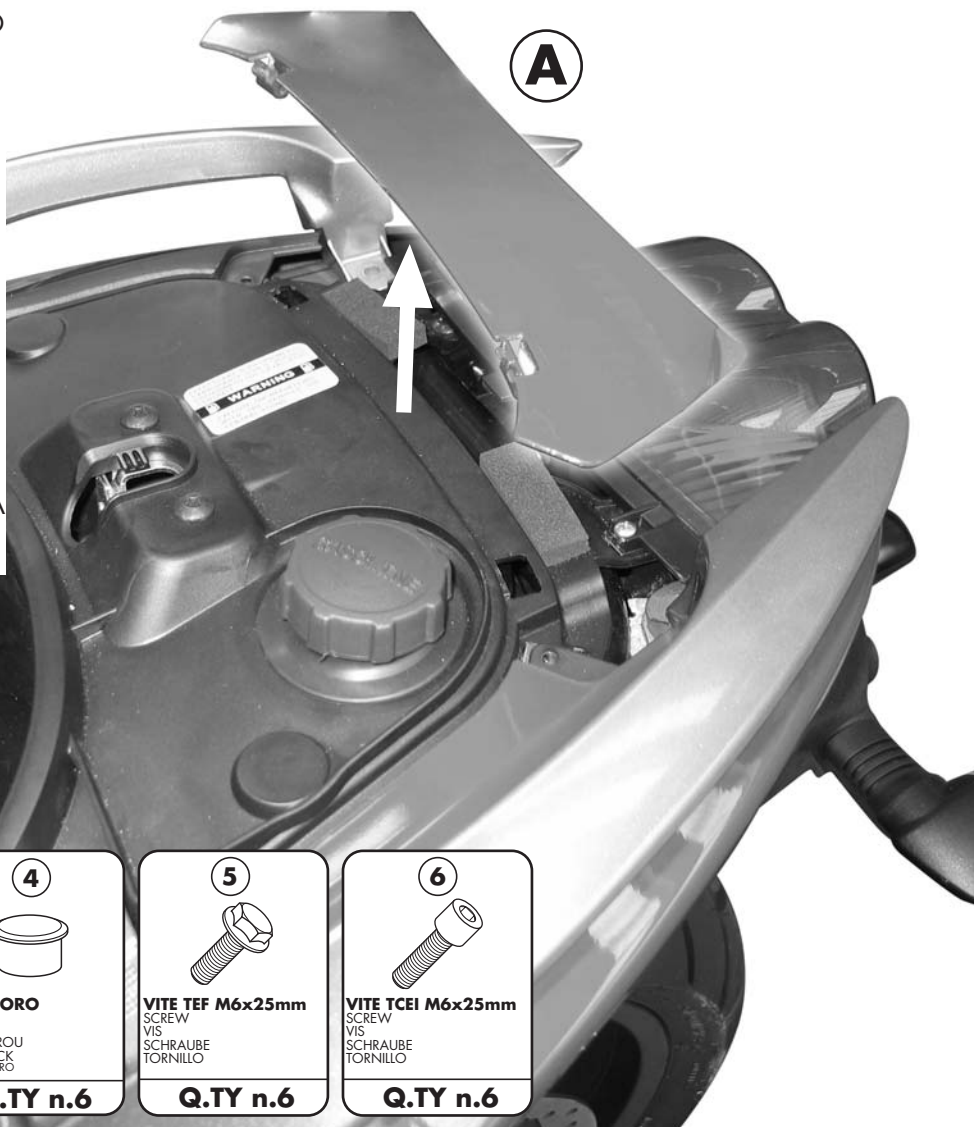

PORTAVALIGIA SPECIFICO - SPECIFIC CASE HOLDER  
 PORTE-VALISE SPECIFIQUE - SPEZIFISCHER KOFFER-TRÄGER  
 PORTA-EQUIPAJE ESPECIFICO

# GILERA GP800 2008

ISTRUZIONI DI MONTAGGIO - MOUNTING INSTRUCTIONS  
 INSTRUCTIONS DE MONTAGE - BAUANLEITUNG - INSTRUCCIONES DE MONTAJE

7



**RONDELLA Ø6x18mm**  
 WASHER Ø6x18mm  
 RONDELLE Ø6x18mm  
 SCHEIBE Ø6x18mm  
 ARANDELA Ø6x18mm

**Q.TY n.6**

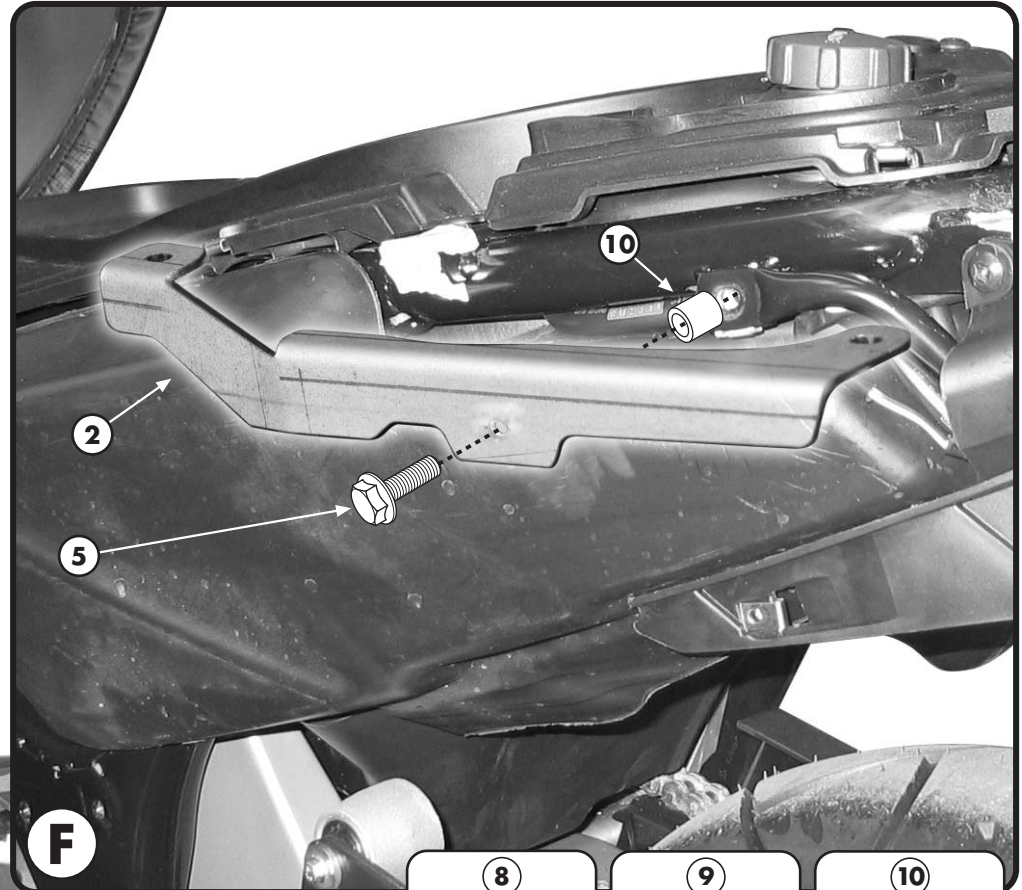
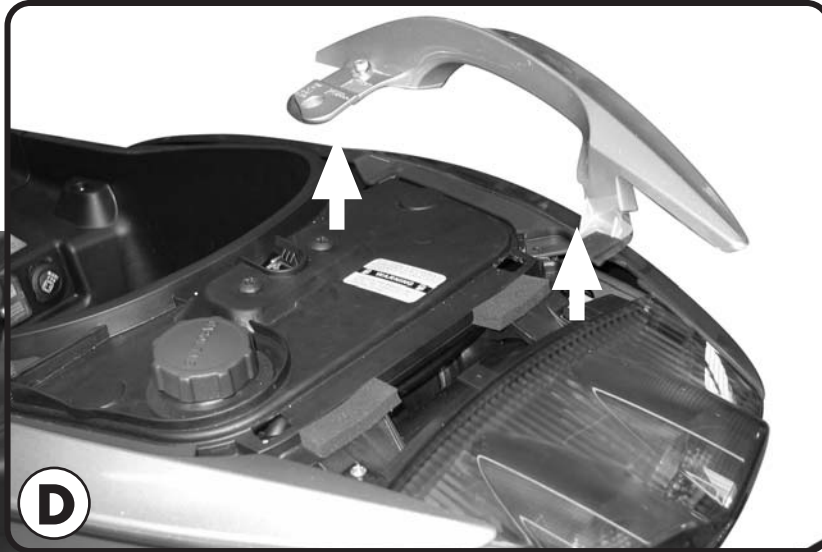

8



**RONDELLA Ø6mm**  
 WASHER Ø6mm  
 RONDELLE Ø6mm  
 SCHEIBE Ø6mm  
 ARANDELA Ø6mm

**Q.TY n.4**

9



**DISTANZIALE Ø14x4mm**  
 Foro Ø6,5mm, V136  
 SPACER  
 ENTRETOISE  
 DISTANZSTUECK  
 DISTANCIADOR

**Q.TY n.2**

10



**DISTANZIALE Ø14x6,5mm**  
 Foro Ø7mm, V134  
 SPACER  
 ENTRETOISE  
 DISTANZSTUECK  
 DISTANCIADOR

**Q.TY n.4**

11



**DADO A.B. M6**  
 BOLT M6  
 ECROU M6  
 MUTTER M6  
 TUERCA M6

**Q.TY n.4**

PORTAVALIGIA SPECIFICO - SPECIFIC CASE HOLDER  
PORTE-VAUSE SPÉCIFIQUE - SPEZIFISCHER KOFFER-TRÄGER  
PORTA-EQUIPAJE ESPECÍFICO

# GILERA GP800 2008

ISTRUZIONI DI MONTAGGIO - MOUNTING INSTRUCTIONS  
INSTRUCTIONS DE MONTAGE - BAUANLEITUNG - INSTRUCCIONES DE MONTAJE

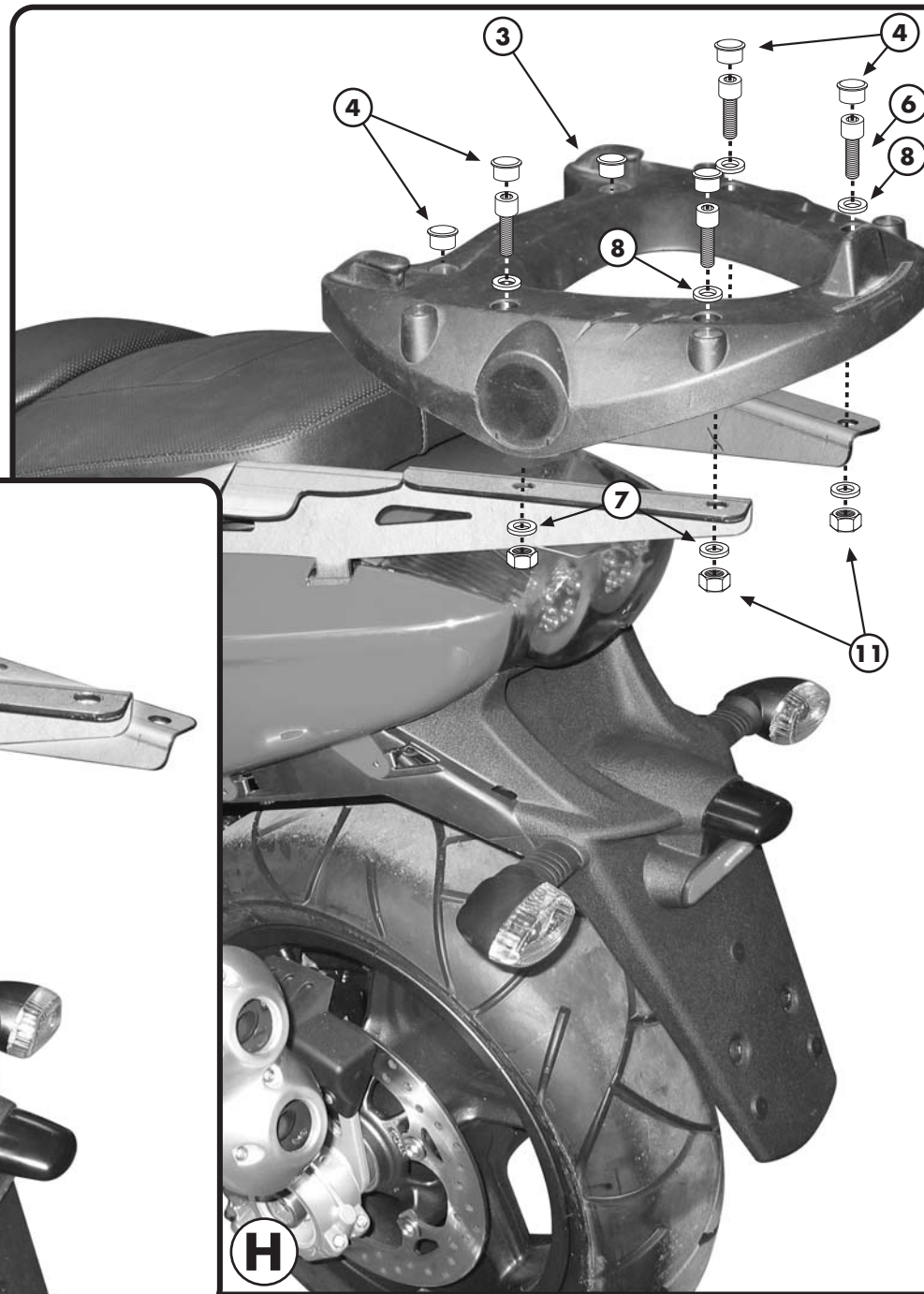
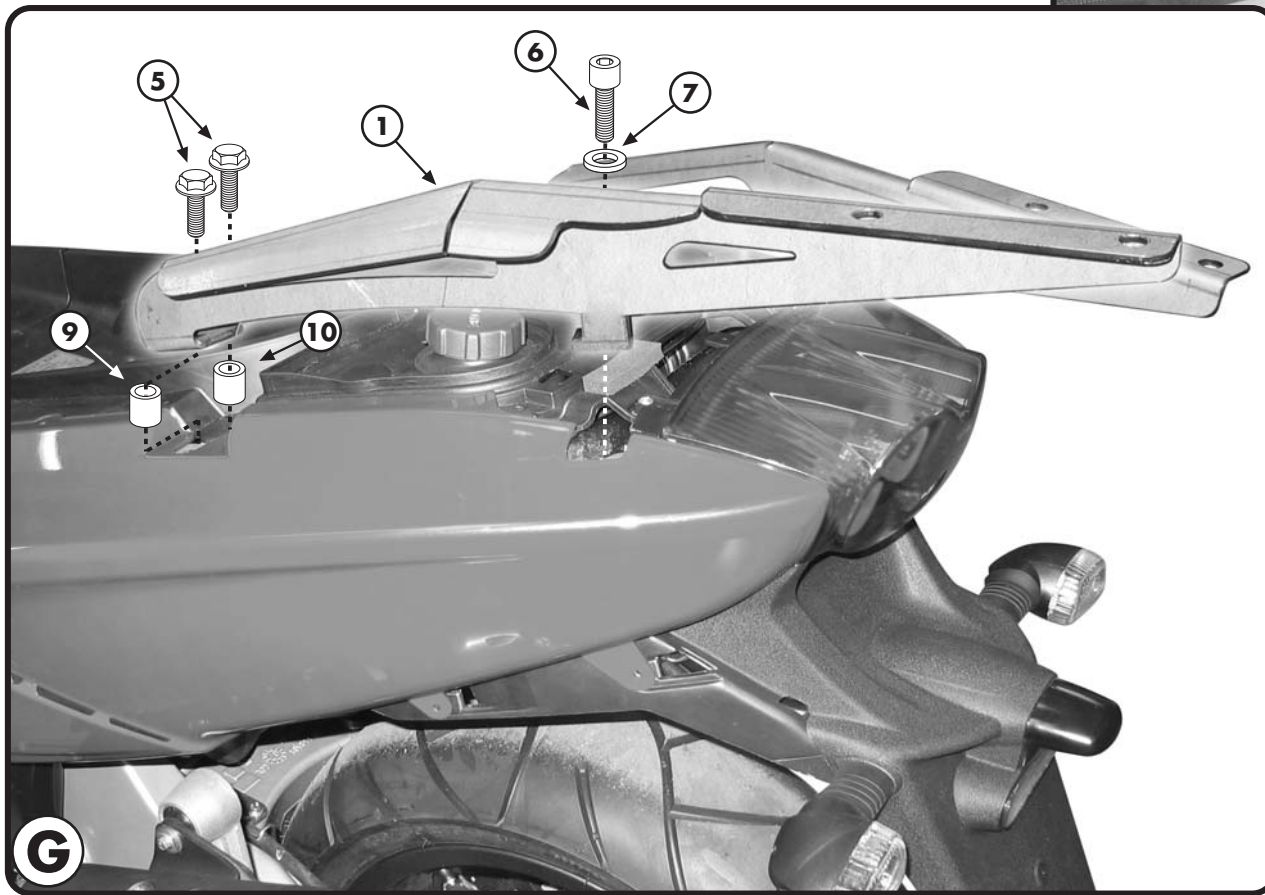

PORTAVALIGIA SPECIFICO - SPECIFIC CASE HOLDER  
 PORTE-VALISE SPÉCIFIQUE - SPEZIFISCHER KOFFER-TRÄGER  
 PORTA-EQUIPAJE ESPECIFICO

**GILERA GP800 2008**

ISTRUZIONI DI MONTAGGIO - MOUNTING INSTRUCTIONS  
 INSTRUCTIONS DE MONTAGE - BAUANLEITUNG - INSTRUCCIONES DE MONTAJE

## I ISTRUZIONI DI MONTAGGIO

1. SMONTARE LE PARTI ORIGINALE INDICATE DALL'IMMAGINE A ALL'IMMAGINE E;
2. MONTARE IL SUPPORTO DI RINFORZO N°2 COME MOSTRATO IN FOTOGRAFIA F;
3. RIMONTARE LE PARTI ORIGINALI SMONTATE IN PRECEDENZA;
4. MONTARE IL SUPPORTO N°1 COME INDICATO IN FOTOGRAFIA G;
5. MONTARE LA PIASTRA PORTAVALIGIA COME INDICATO IN FOTOGRAFIA H;
6. ULTIMARE IL MONTAGGIO VERIFICANDO CHE TUTTE LE VITI SIANO SERRATE BENE (VITI M6=9,6Nm - VITI M8=23Nm) E CHE IL TAPPO ANTIFURTO ED I GOMMINI SIANO MONTATI CORRETTAMENTE SULLA PIASTRA.

## GB MOUNTING INSTRUCTIONS

1. DISASSEMBLE THE REAR SECTION OF THE BIKE AS SHOWN IN PICTURES A THROUGH E.
2. SET IN PLACE THE REINFORCEMENT SUPPORT (ITEM #2) AND INSTALL AS SHOWN IN PICTURE F.
3. REASSEMBLE THE REAR OF THE BIKE EXCEPT FOR THE PASSENGER GRAB HANDLES.
4. POSITION THE PLATE SUPPORT (ITEM #1) AND INSTALL AS SHOWN IN PICTURE G.
5. POSITION THE PLATE AND INSTALL AS SHOWN IN PICTURE H.
6. MAKE SURE THAT ALL THE NUTS AND BOLTS ARE TIGHTEN APPROPRIATELY (BOLTS M6=9.6NM - BOLTS M8=23NM).
7. INSURE THAT THE ANTI THEFT CAP AND RUBBER BUMPERS ARE CORRECTLY INSTALLED IN THE PLATE.

## F INSTRUCTIONS DE MONTAGE

1. DEMONTER LES PIÈCES D'ORIGINE COMME INDIQUE DE LA PHOTO "A" A LA PHOTO E;
2. MONTER LES SUPPORTS DE RÉNFORT N°2 COMME INDIQUE EN PHOTO F;
3. REMONTER LES PIÈCES D'ORIGINE PRECEDEMMENT DEMONTEES;
4. MONTER LES SUPPORTS N°1 COMME INDIQUE EN PHOTO G;
5. MONTER LA PLATINE PORTE-VALISE COMME INDIQUE EN PHOTO H;
6. TERMINER LE MONTAGE EN CONTROLANT LE BON SERRAGE DE TOUTES LES VIS (VIS M6=9,6Nm - VIS M8=23Nm) ET VERIFIER QUE LE BOUCHON ANTIVOL ET LES CAOUTCHOUCS SOIENT CORRECTEMENT MONTES SUR LA PLATINE.

## D BAUANLEITUNG

1. DEMONTIEREN SIE DIE ORIGINALTEILE, DIE IN DEN BILDERN VON A BIS E GEZEIGT;
2. MONTIEREN SIE DIE HALTERUNG NR. 2 WIE IM BILD F GEZEIGT;
3. BEFESTIGEN SIE DIE ORIGINALTEILE WIEDER DIE SIE ENTFERNT HABEN;
4. MONTIEREN SIE DIE HALTERUNG NR. 1 WIE IM BILD G GEZEIGT;
5. MONTIEREN SIE DIE TRÄGERPLATTE WIE IM BILD H HINGEWIESEN;
6. ZULETZT ÜBERPRÜFEN SIE DASS ALLE SCHRAUBEN (SCHRAUBEN M6=9,6NM - SCHRAUBEN M8=23NM) FESTGEZOGEN WURDEN UND DASS DIE DIEBSTAHLSTÖPSEL UND DIE GUMMISTÖPSEL AUF DER PLATTE KORREKT MONTIERT WURDEN.

## ES

## INSTRUCCIONES DE MONTAJE

1. DESMONTAR LAS PIEZAS ORIGINALES COMO SE MUESTRA DE LA IMAGEN A A LA E;
2. MONTAR EL SOPORTE DE REFUERZO N°2 COMO MUESTRA LA IMAGEN F;
3. VOLVER A MONTAR LAS PIEZAS ORIGINALES DESMONTADAS ANTERIORMENTE;
4. MONTAR EL SOPORTE N° 1 COMO SE INDICA EN LA IMAGEN G;
5. MONTAR LA PARRILLA COMO MUESTRA LA IMAGEN H;
6. TERMINAR EL MONTAJE COMPROBANDO QUE TODOS LOS TORNILLOS ESTÉN BIEN APRETADOS (TORNILLOS M6=9,6NM - TORNILLOS M8=23NM) Y QUE EL TAPON ANTIRROBO Y LAS GOMAS ESTÉN MONTADOS CORRECTAMENTE EN LA PARRILLA.