

SRT127M - KR127M

PORTAVALIGIA SPECIFICO - SPECIFIC CASE HOLDER
PORTE-VAISE SPECIFIQUE - SPEZIFISCHER KOFFER-TRÄGER
PORTA-EQUIPAJE ESPECIFICO

GILERA GP800 2008

ISTRUZIONI DI MONTAGGIO - MOUNTING INSTRUCTIONS
INSTRUCTIONS DE MONTAGE - BAUANLEITUNG - INSTRUCCIONES DE MONTAJE



ATTENZIONE: PESO
MASSIMO
SOPPORTABILE
10Kg.

WARNING:
MAX. LOADING OF
THE CARRIER
10Kg. (21lbs)

ATTENTION:
CHARGE MAXIMALE
10Kg.

ACHTUNG:
MAXIMALE
BELASTUNG 10Kg.

¡ATENCIÓN!: CARGA
MAXIMA
AUTORIZADA 10Kg.

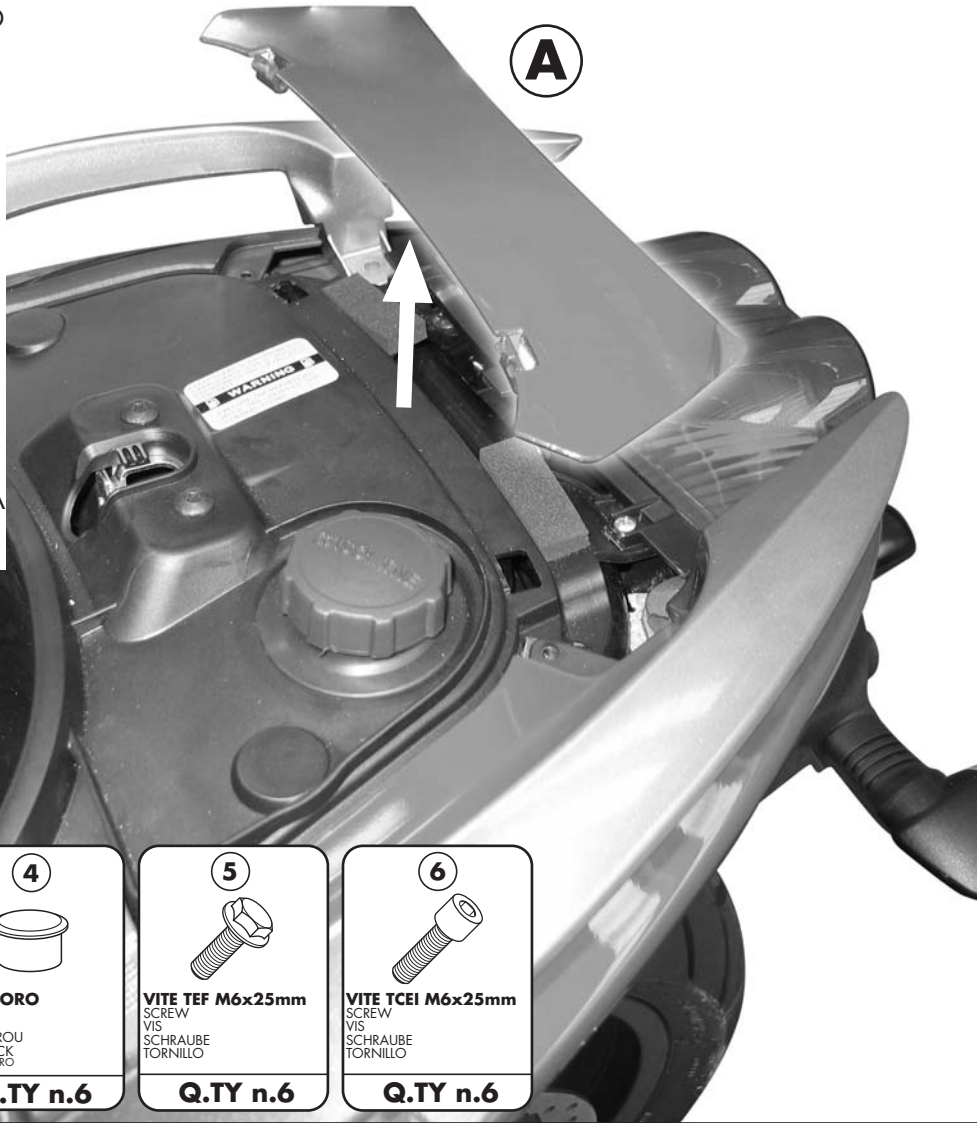

PORTAVALIGIA SPECIFICO - SPECIFIC CASE HOLDER
 PORTE-VALISE SPECIFIQUE - SPEZIFISCHER KOFFER-TRÄGER
 PORTA-EQUIPAJE ESPECIFICO

GILERA GP800 2008

ISTRUZIONI DI MONTAGGIO - MOUNTING INSTRUCTIONS
 INSTRUCTIONS DE MONTAGE - BAUANLEITUNG - INSTRUCCIONES DE MONTAJE

7



RONDELLA Ø6x18mm
 WASHER Ø6x18mm
 RONDELLE Ø6x18mm
 SCHEIBE Ø6x18mm
 ARANDELA Ø6x18mm

Q.TY n.6

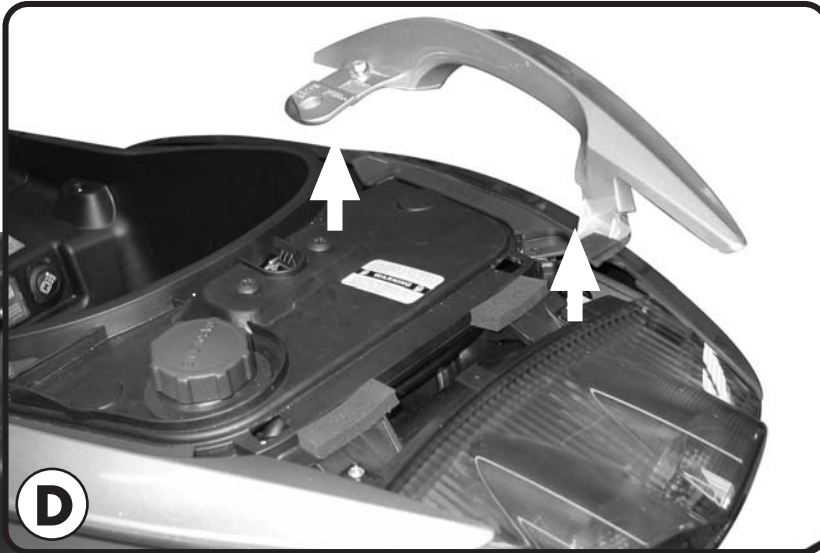

D

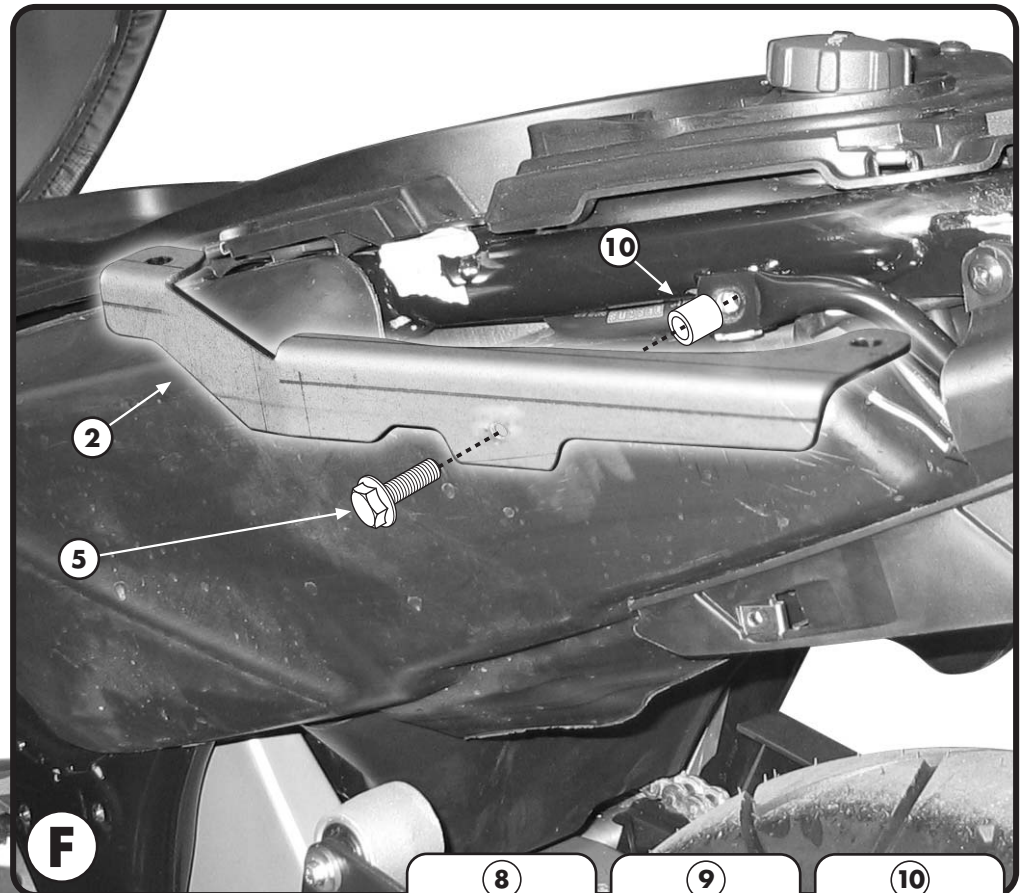

F



E

8



RONDELLA Ø6mm
 WASHER Ø6mm
 RONDELLE Ø6mm
 SCHEIBE Ø6mm
 ARANDELA Ø6mm

Q.TY n.4

9



DISTANZIALE Ø14x4mm
 Foro Ø6,5mm, V136
 SPACER
 ENTRETOISE
 DISTANZSTUECK
 DISTANCIADOR

Q.TY n.2

10



DISTANZIALE Ø14x6,5mm
 Foro Ø7mm, V134
 SPACER
 ENTRETOISE
 DISTANZSTUECK
 DISTANCIADOR

Q.TY n.4

11



DADO A.B. M6
 BOLT M6
 ECROU M6
 MUTTER M6
 TUERCA M6

Q.TY n.4

SRI27M - KR127M

PORTAVALIGIA SPECIFICO - SPECIFIC CASE HOLDER
PORTE-VALISE SPECIFIQUE - SPEZIFISCHER KOFFER-TRÄGER
PORTA-EQUIPAJE ESPECIFICO

GILERA GP800 2008

ISTRUZIONI DI MONTAGGIO - MOUNTING INSTRUCTIONS
INSTRUCTIONS DE MONTAGE - BAUANLEITUNG - INSTRUCCIONES DE MONTAJE

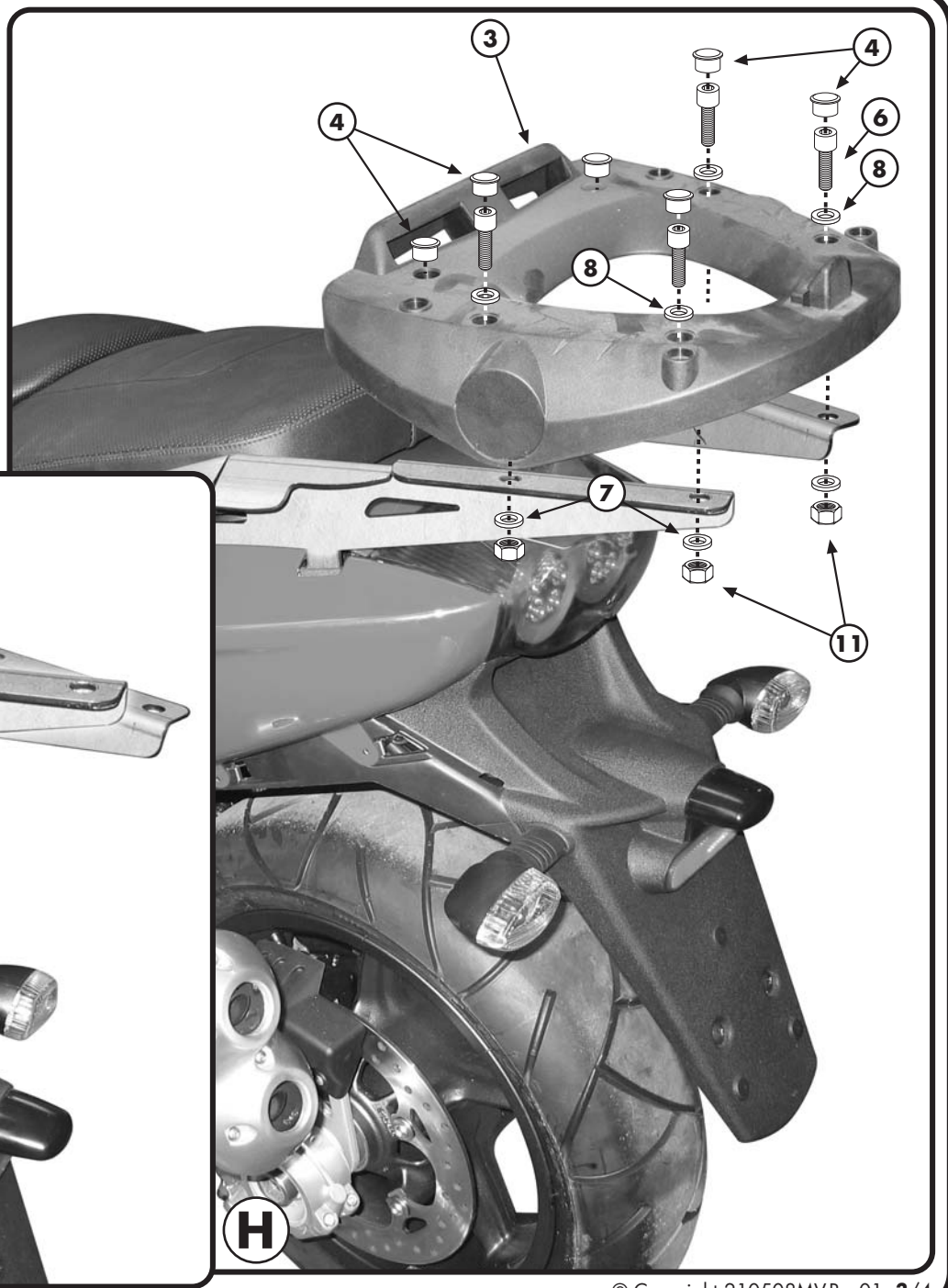
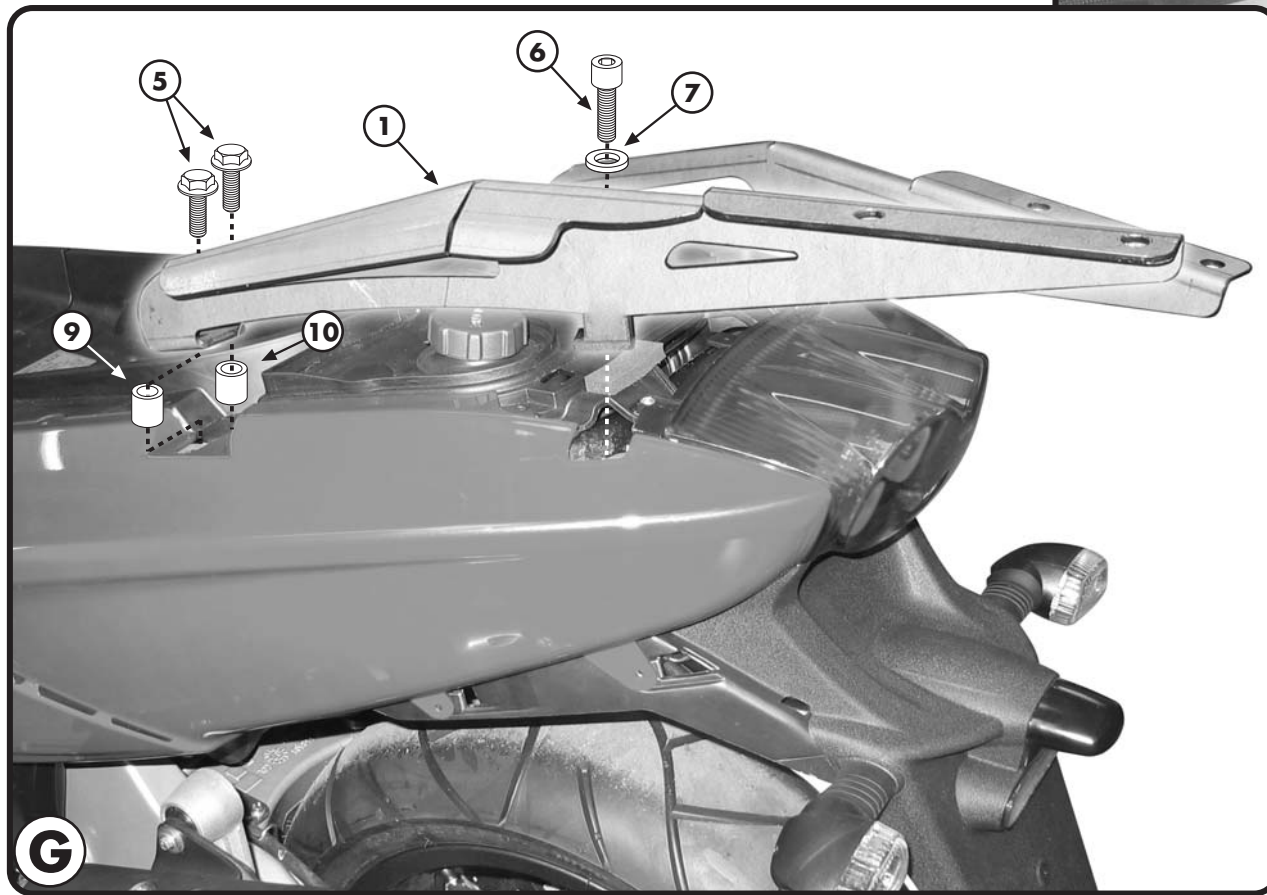

PORTAVALIGIA SPECIFICO - SPECIFIC CASE HOLDER
 PORTE-VALISE SPECIFIQUE - SPEZIFISCHER KOFFER-TRÄGER
 PORTA-EQUIPAJE ESPECIFICO

GILERA GP800 2008

ISTRUZIONI DI MONTAGGIO - MOUNTING INSTRUCTIONS
 INSTRUCTIONS DE MONTAGE - BAUANLEITUNG - INSTRUCCIONES DE MONTAJE

I ISTRUZIONI DI MONTAGGIO

1. SMONTARE LE PARTI ORIGINALE INDICATE DALL'IMMAGINE A ALL'IMMAGINE E;
2. MONTARE IL SUPPORTO DI RINFORZO N°2 COME MOSTRATO IN FOTOGRAFIA F;
3. RIMONTARE LE PARTI ORIGINALI SMONTATE IN PRECENDENZA;
4. MONTARE IL SUPPORTO N°1 COME INDICATO IN FOTOGRAFIA G;
5. MONTARE LA PIASTRA PORTAVALIGIA COME INDICATO IN FOTOGRAFIA H;
6. ULTIMARE IL MONTAGGIO VERIFICANDO CHE TUTTE LE VITI SIANO SERRATE BENE (VITI M6=9,6Nm - VITI M8=23Nm) E CHE IL TAPPO ANTIFURTO ED I GOMMINI SIANO MONTATI CORRETTAMENTE SULLA PIASTRA.

GB MOUNTING INSTRUCTIONS

1. DISASSEMBLE THE REAR SECTION OF THE BIKE AS SHOWN IN PICTURES A THROUGH E.
2. SET IN PLACE THE REINFORCEMENT SUPPORT (ITEM #2) AND INSTALL AS SHOWN IN PICTURE F.
3. REASSEMBLE THE REAR OF THE BIKE EXCEPT FOR THE PASSENGER GRAB HANDLES.
4. POSITION THE PLATE SUPPORT (ITEM #1) AND INSTALL AS SHOWN IN PICTURE G.
5. POSITION THE PLATE AND INSTALL AS SHOWN IN PICTURE H.
6. MAKE SURE THAT ALL THE NUTS AND BOLTS ARE TIGHTEN APPROPRIATELY (BOLTS M6=9.6NM - BOLTS M8=23NM).
7. INSURE THAT THE ANTITHEFT CAP AND RUBBER BUMPERS ARE CORRECTLY INSTALLED IN THE PLATE.

F INSTRUCTIONS DE MONTAGE

1. DEMONTER LES PIECES D'ORIGINE COMME INDIQUE DE LA PHOTO "A" A LA PHOTO E;
2. MONTER LES SUPPORTS DE RENFORT N°2 COMME INDIQUE EN PHOTO F;
3. REMONTER LES PIECES D'ORIGINE PRECEDEMMENT DEMONTEES;
4. MONTER LES SUPPORTS N°1 COMME INDIQUE EN PHOTO G;
5. MONTER LA PLATINE PORTE-VALISE COMME INDIQUE EN PHOTO H;
6. TERMINER LE MONTAGE EN CONTROLANT LE BON SERRAGE DE TOUTES LES VIS (VIS M6=9,6Nm - VIS M8=23Nm) ET VERIFIER QUE LE BOUCHON ANTIVOL ET LES CAOUTCHOUCS SOIENT CORRECTEMENT MONTES SUR LA PLATINE.

D BAUANLEITUNG

1. DEMONTIEREN SIE DIE ORIGINALTEILE, DIE IN DEN BILDERN VON A BIS E GEZEIGT;
2. MONTIEREN SIE DIE HALTERUNG NR. 2 WIE IM BILD F GEZEIGT;
3. BEFESTIGEN SIE DIE ORIGINALTEILE WIEDER DIE SIE ENTFERNT HABEN;
4. MONTIEREN SIE DIE HALTERUNG NR. 1 WIE IM BILD G GEZEIGT;
5. MONTIEREN SIE DIE TRÄGERPLATTE WIE IM BILD H HINGEWIESEN;
6. ZULETZT ÜBERPRÜFEN SIE DASS ALLE SCHRAUBEN (SCHRAUBEN M6=9,6NM - SCHRAUBEN M8=23NM) FESTGEZOGEN WURDEN UND DASS DIE DIEBSTAHLSTÖPSEL UND DIE GUMMISTÖPSEL AUF DER PLATTE KORREKT MONTIERT WURDEN.

ES

INSTRUCCIONES DE MONTAJE

1. DESMONTAR LAS PIEZAS ORIGINALES COMO SE MUESTRA DE LA IMAGEN A A LA E;
2. MONTAR EL SOPORTE DE REFUERZO N°2 COMO MUESTRA LA IMAGEN F;
3. VOLVER A MONTAR LAS PIEZAS ORIGINALES DESMONTADAS ANTERIORMENTE;
4. MONTAR EL SOPORTE N° 1 COMO SE INDICA EN LA IMAGEN G;
5. MONTAR LA PARRILLA COMO MUESTRA LA IMAGEN H;
6. TERMINAR EL MONTAJE COMPROBANDO QUE TODOS LOS TORNILLOS ESTÉN BIEN APRETADOS (TORNILLOS M6=9,6NM - TORNILLOS M8=23NM) Y QUE EL TAPON ANTIRROBO Y LAS GOMAS ESTÉN MONTADOS CORRECTAMENTE EN LA PARRILLA.